

Z:\15-0086-65\DWG\PRODUCTION DRAWINGS\PRE DEVELOPMENT PLAN\PCP.dwg Sheet 1 Feb 13, 2017 - 12:36:25pm [etchal]

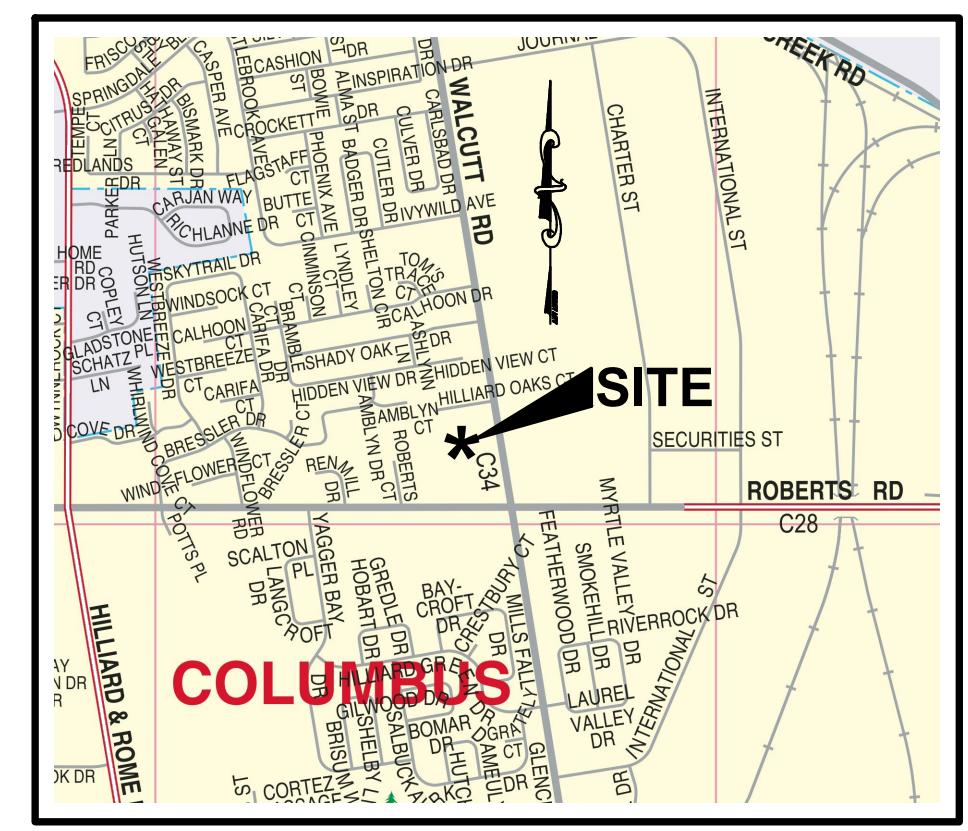
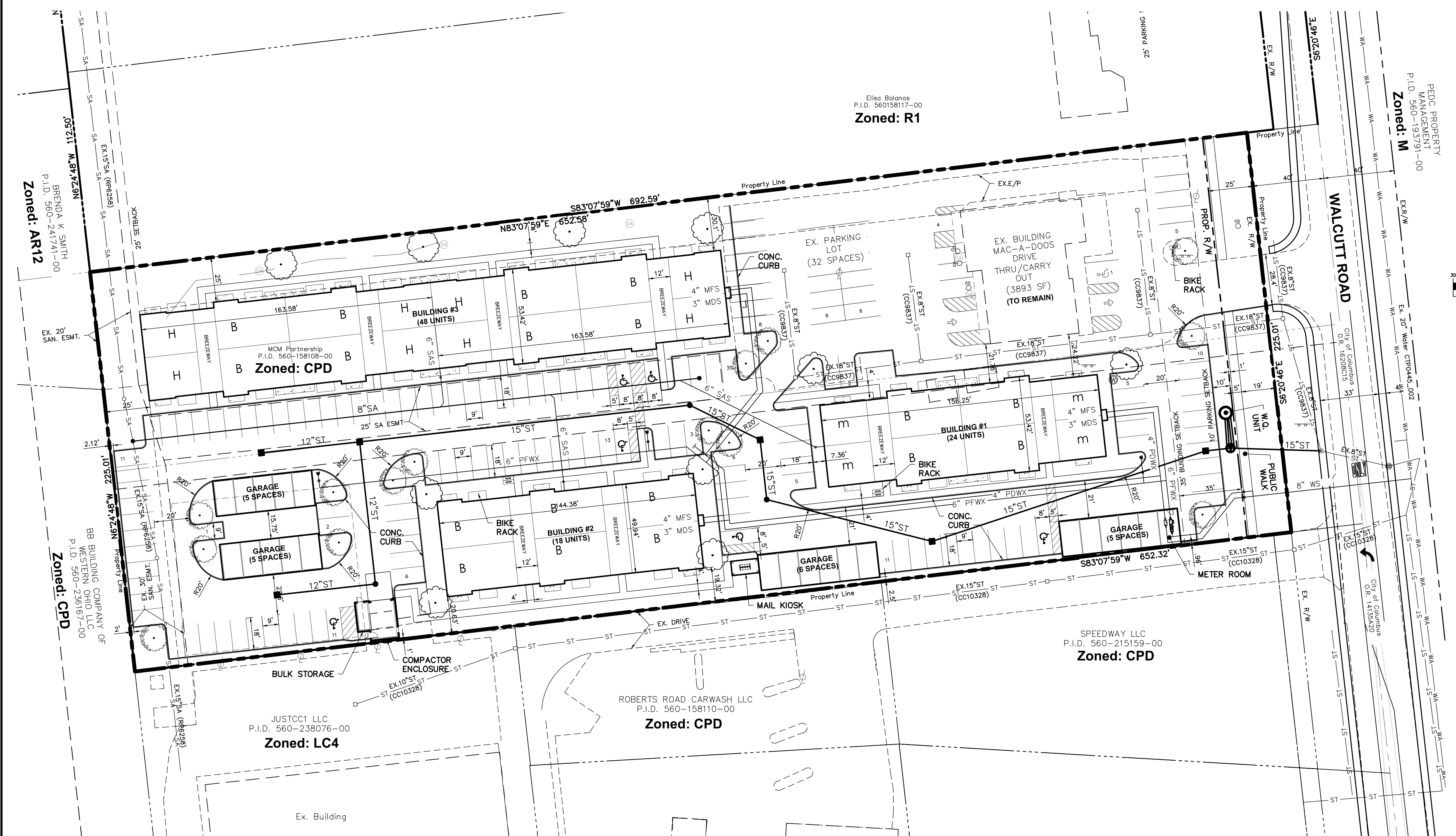

LOCATION MAP
NO SCALE

DEVELOPER
PREFERRED LIVING
750 COMMUNICATIONS PARKWAY
COLUMBUS, OHIO 43221
PHONE (614) 901-2400
FAX (614) 901-3301

ENGINEER
ADVANCED CIVIL DESIGN, INC.
422 BEECHER ROAD
GAHANNA, OH 43230
PHONE (614) 428-7750
FAX (614) 428-7755

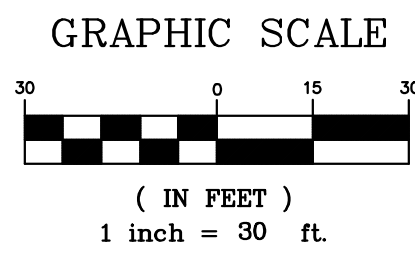

SITE DATA SUMMARY:

TOTAL PROPERTY AREA:	3.370 ACRES
PUBLIC ROW DEDICATION AREA:	0.129 ACRES
NET PROPERTY AREA:	3.241 ACRES
P.I.D.:	560-158108-00
NO. BUILDINGS:	3 HOTEL BUILDINGS 1 EXISTING RETAIL (MAC-A-DOOS PUB & DRIVE-THRU)
RESIDENTIAL:	TOTAL SUITES: 90 1 BEDROOM SUITES: 48 SUITES 2 BEDROOM SUITES: 42 SUITES DENSITY: 26.7 SUITES / ACRE
UNIT BREAKDOWN:	UNIT B - 2 BEDROOM (42 SUITES) UNIT M - 1 BEDROOM (24 SUITES) UNIT H - 1 BEDROOM (24 SUITES)

PARKING CALCULATIONS:

RESIDENTIAL	
SUITES:	90
TOTAL SPACES REQUIRED:	1.5 SPACES/SUITE = 135 (INCL. 5 HC)
TOTAL SPACES PROVIDED:	150 (9 W/H.C. ACCESS) (129 SURFACE SPACES, 21 GARAGE SPACES) 1.67 SPACES/SUITE
BICYCLE PARKING REQUIRED:	1 SPACE/20 VEHICULAR SPACES (W/ A MAX OF 20) 150 X (1/20) = 8 BICYCLE SPACES
BICYCLE PARKING PROVIDED:	8 BICYCLE SPACES (4~U TYPE RACKS)
RETAIL	
TOTAL SPACES REQUIRED:	1:175 SF (3893/175) = 23 SPACES 1 H.C. REQUIRED (1 VAN)
TOTAL SPACES PROVIDED:	23 (1 W/H.C. ACCESS)
BICYCLE PARKING REQUIRED:	1 SPACE/20 VEHICULAR SPACES (W/ A MAX OF 20) 23 X (1/20) = 2 BICYCLE SPACES
BICYCLE PARKING PROVIDED:	2 BICYCLE SPACES (1~U TYPE RACKS)
TOTALS	
TOTAL SPACES REQUIRED:	23 (RETAIL) + 135 (RES.) = 158 SPACES
TOTAL SPACES PROVIDED:	23 (RETAIL) + 150 (RES.) = 173 SPACES

PARKING SPACE SHADE TREES REQUIRED:	1 PER 10 PARKING SPACES = 17 TREES
PARKING SPACE SHADE TREES PROVIDED:	17 TREES
LANDSCAPE TREES REQUIRED:	1 PER 10 DWELLING UNITS = 10 TREES
LANDSCAPE TREES PROVIDED:	10 TREES

SITE DATA TABLE

TOTAL SITE AREA:	3.370 AC
TOTAL DISTURBED AREA:	3.521 AC
PRE-DEVELOPED IMPERVIOUS AREA:	0.885 AC
POST-DEVELOPED IMPERVIOUS AREA:	2.574 AC

CITY OF COLUMBUS, OHIO
PRELIMINARY SITE COMPLIANCE PLAN FOR WALCUTT ROAD EXTENDED STAY

PLAN PREPARED BY:
ADVANCED CIVIL DESIGN ENGINEERS SURVEYORS

422 BEECHER ROAD
GAHANNA, OHIO 43230
ph 614.428.7750
fax 614.428.7755

SANITARY SEWER CAPOFF NOTE:
SEWER CAPOFF PERMIT IS REQUIRED PRIOR TO ISSUANCE OF DEMOLITION PERMIT. OBTAIN A CAPOFF PERMIT FROM THE SEWER PERMIT OFFICE AT 910 DUBLIN ROAD, 645-7490.

SANITARY SEWER NOTE:
CONNECTION TO SANITARY SEWER CANNOT BE MADE WITHOUT OBTAINING A PERMIT FROM SEWER PERMIT OFFICE 910 DUBLIN ROAD 3RD FLOOR, 645-7490.

STORM SEWER PLAN: CC-XXXX
SANITARY SEWER PLAN: CC-XXXX
PRIVATE WATER SERVICE PLAN: #XXXX
DE. E PLAN: XXXX-E

FLOOD INSURANCE RATE MAP NUMBER: 39049C0144K
COMMUNITY PANEL: 144 OF 465
ZONE X
EFFECTIVE DATE: JUNE 17, 2008

OHIO EPA FACILITY PERMIT NUMBER: N/A

- THE PROJECT COMPLIES WITH THE FOLLOWING SECTIONS OF THE COLUMBUS ZONING CODES:
- 3321.01 DUMPSTER
 - 3321.07 LANDSCAPE
 - 3321.03 LIGHTING
 - 3312.21 SCREENS
 - 3312.39 STRIPING/MARKING
 - 3312.43 SURFACE
 - 3312.45 WHEEL STOPS/CURB

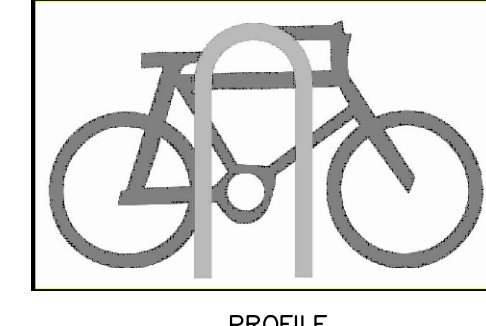
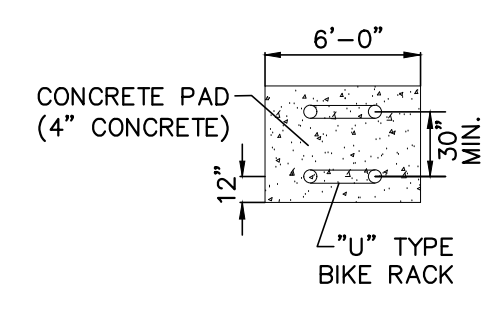

BIKE RACK DETAILS

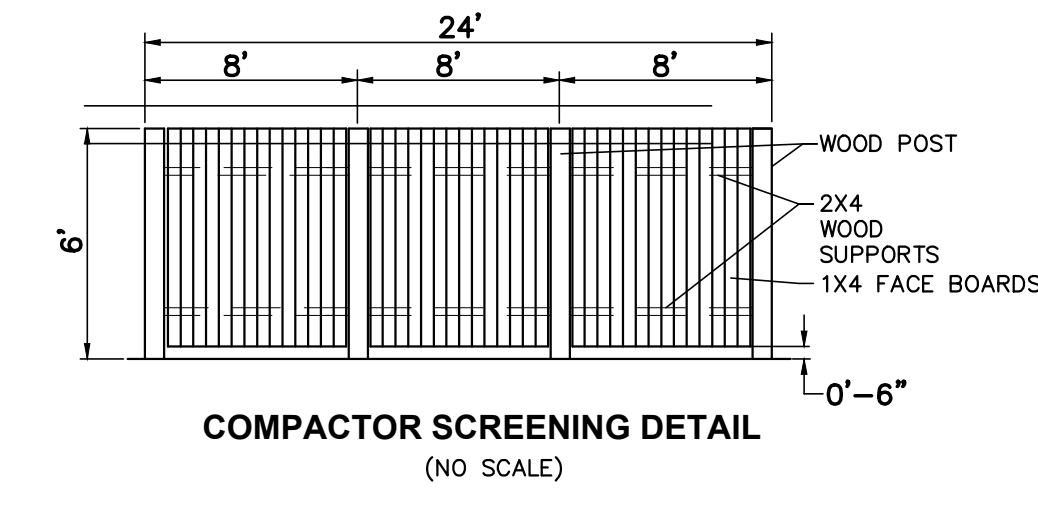
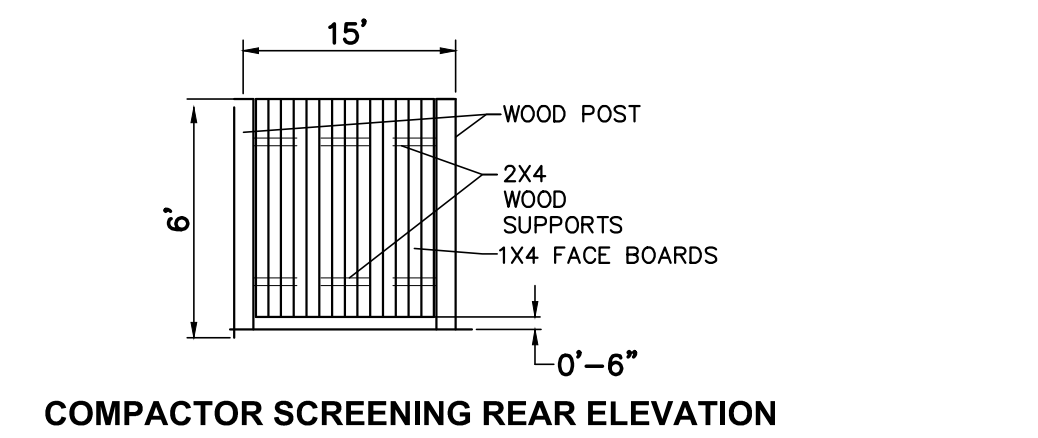

TREE AND SHRUB TRIMMING IS LIMITED TO 1/3 OF ANY BRANCH WHEN PRUNING UNLESS BRANCHES ARE DEAD OR INJURED FROM

TREES, SHRUBS & EVERGREENS ARE TO BE PLANTED AT THE SAME GRADE AS GROWN IN NURSERY.

RUBBER HOSE TREE PROTECTION
1 PER TREE UP TO 8' HGT.

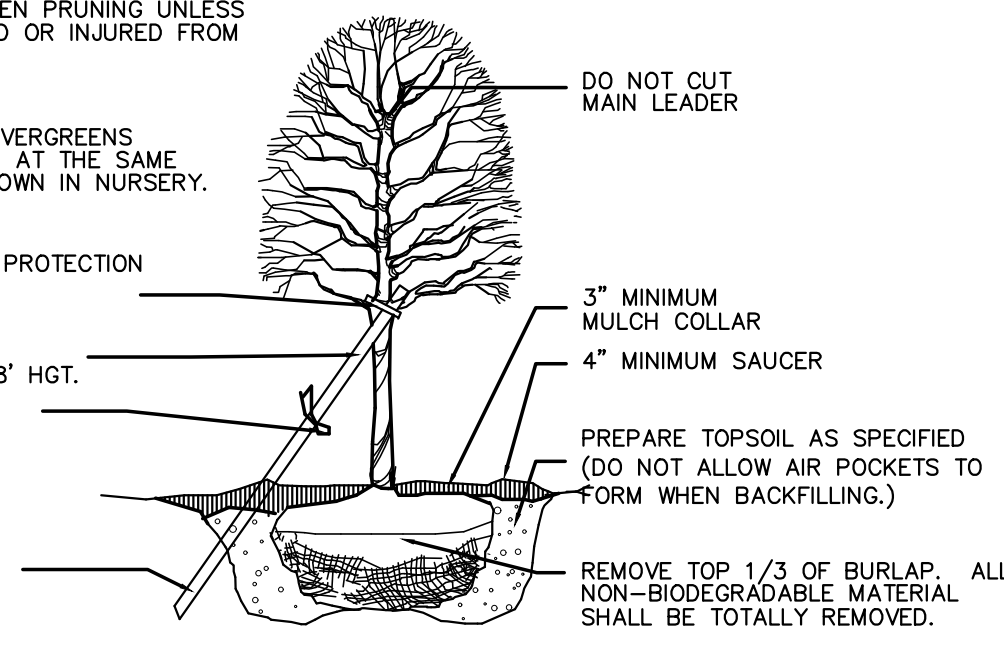

DECIDUOUS TREE UNDER 3" CALIPER

DO NOT CUT MAIN LEADER

3" MINIMUM MULCH COLLAR
4" MINIMUM SAUCER

PREPARE TOPSOIL AS SPECIFIED (DO NOT ALLOW AIR POCKETS TO FORM WHEN BACKFILLING.)
REMOVE TOP 1/3 OF BURLAP. ALL NON-BIODEGRADABLE MATERIAL SHALL BE TOTALLY REMOVED.